



QA CHECKLIST	
Fabricator	
Date Issued	
Time Start	
Time finish	
Preweld Check	
Final Check	

ASSEMBLY	GRID LOCATION
B/100	D/5-3

- GENERAL NOTES
- HOLES 22 DIA. FOR 8.8S BOLTS UNLESS NOTED.
 - ALL WELDS TO BE 6 CFW, E48XX UNLESS NOTED OTHERWISE.
 - ALL BUTT WELDS TO BE FULL PENETRATION UNLESS NOTED.
 - ALL NOTCHES TO HAVE 10mm RADIUS AT INTERNAL CORNERS.
 - ASSEMBLY MARK TO BE STAMPED ON TOP FACE WHERE INDICATED THUS .
 - THIS SYMBOL <  INDICATES CONNECTING FACE OF CLEAT.

SUB-ASSEMBLY REF.	
No.	In Assembly.
1	ALONE

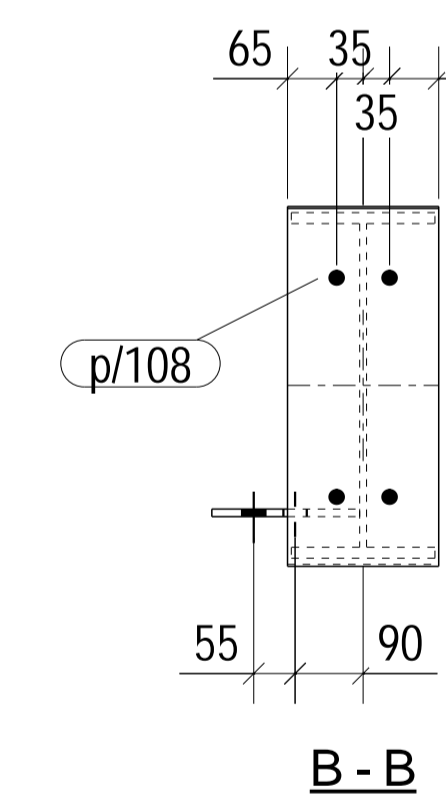
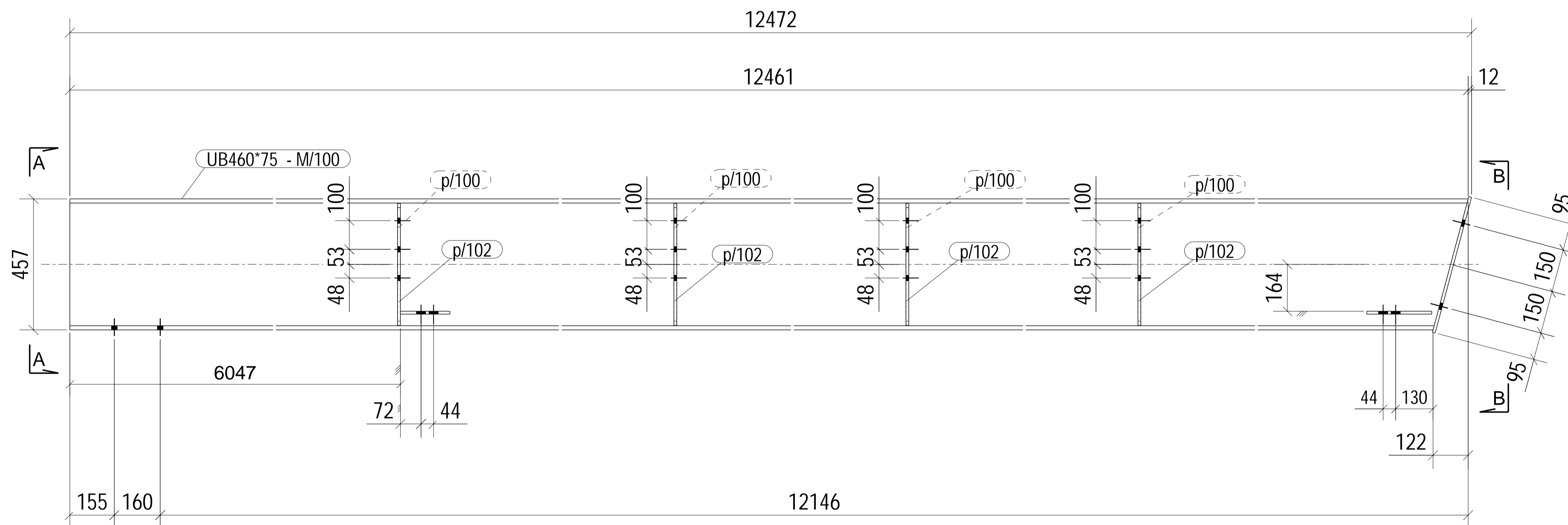
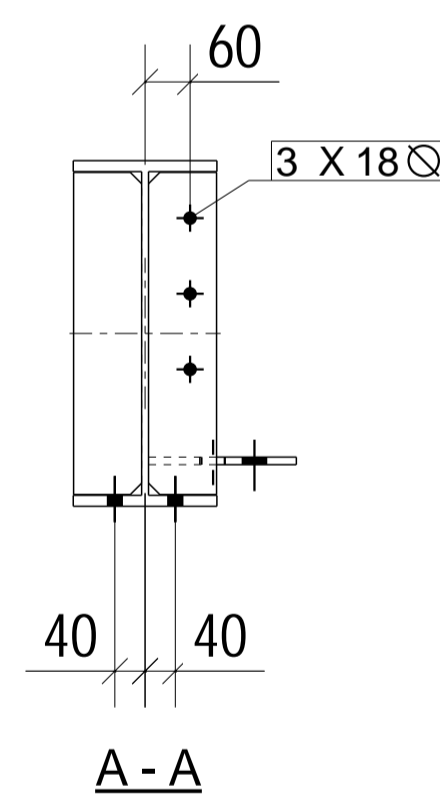
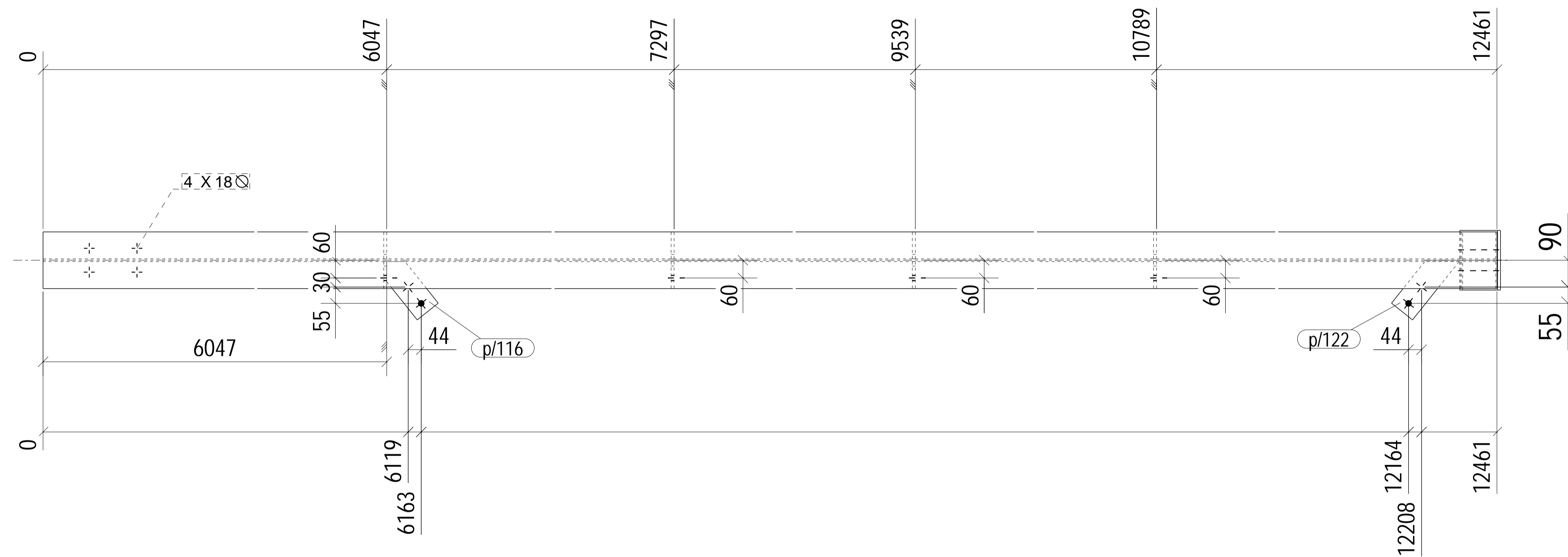

MATERIAL LIST						
ITEM	No.OFF	SECTION	LENGTH	GRADE	WEIGHT(kg)	AREA(m ²)
M/100	1	UB460*75	12461	300	931.2	20.4
p/100	4	FL10*90	426	250	12.0	0.3
p/102	4	FL10*90	426	250	12.0	0.3
p/108	1	FL10*200	490	250	7.7	0.2
p/116	1	FL10*90	217	250	1.4	0.0
p/122	1	FL10*90	250	250	1.5	0.0
TOTAL					965.7	21.4

PHASE	QTY.
1	1

1 BEAM[S] REQ'D AS DRAWN MK B/100
Finish - HOT DIP GALVANISED

0	19.05.2015	For Construction
REV	DATE	DESCRIPTION
CONFIDENTIAL		
DRAWING TITLE		BEAM
CONTRACT		Chiller platform
MODELLED BY	B.A.	ISSUE DATE 23.05.2016
JOB NUMBER	245151	DRAWING No
SCALE	1:10	B/100
		SHEET No
		REV
		O

ASC
 Atkins Steelcraft. Pty Ltd
 Structural Steel Detailing
 Phone: 07 3807 6424